

milk dispenser

Client: 

- Styled to complement client's corporate image
- Multiple style variants
- Tough durable design
- Working with external marketing agency

Brief:

Autonumis is part of a group of companies that investigate opportunities in milk, wine and beer dispensing. In collaboration with the Milk Marketing Board, they recruited SA to design and develop a refrigerated unit for the dispensing of milk from pre-packed cartons for office use.

Solution:

SA initially researched the possible form of the internal carton, which would eventually impact on the product external footprint. Therefore the range of designs allowed for either round or square cartons.

Sadler Associates solution was to produce a range of designs that supported Autonumis's style based corporate image and to reinforce their strength in this sector. The 'Milk Coola' models were designed to build on the client's 3 and 5 gallon machines previously designed by SA.

Result:

The project resulted in three well styled units for Autonumis to develop and launch alongside their existing range.

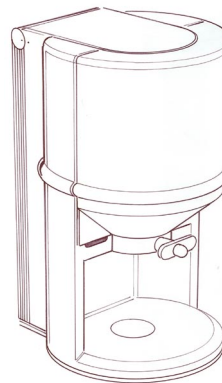
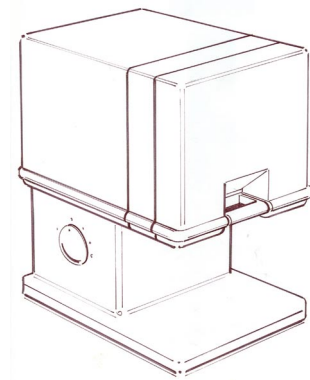

design studio
product design
architecture

